

Spheric

Assembly Instructions Instructions d'assemblage

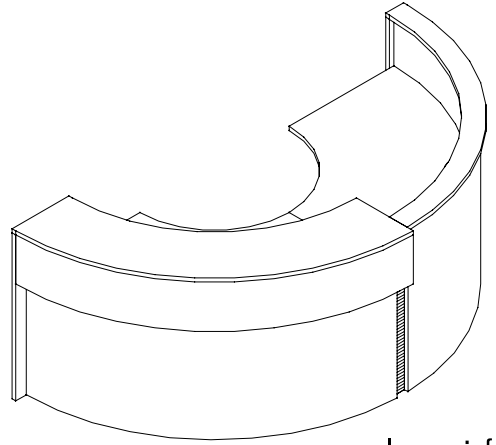

logiflex

Components | Pièces

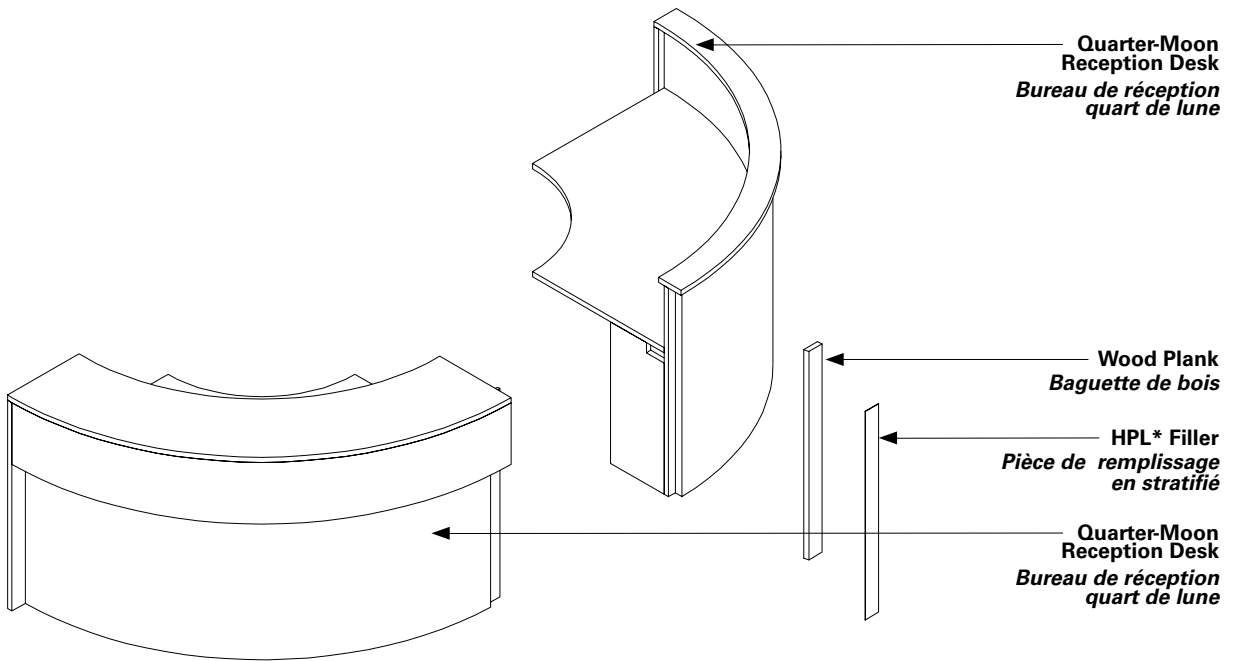

*HPL: High pressure laminate

Hardware | Quincaillerie

Screw | Vis
#8, 1-1/2"



7 - 8x

Flush plate
Plaque de jonction

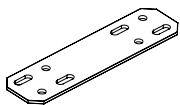

2x

Screw | Vis
#8, 1"



16x

1 Assembling the Reception Counter Bases | *Assemblage des bases du comptoir de réception*

- 1.1 Assemble the reception counters with the flush plates and screws. | *Assemblez les comptoirs de réception avec les plaques de jonction et les vis.*
- 1.2 Tighten the Cams and hide them with Cam covers. | *Visser les Cam et coller les cache-Cam.*

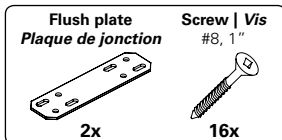
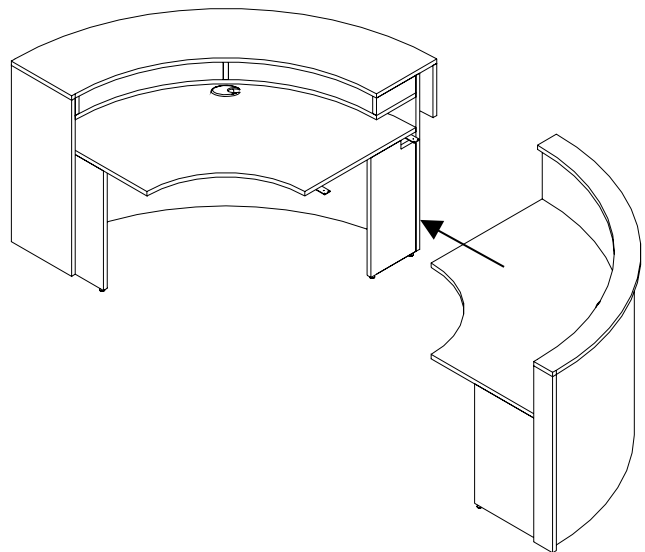

2 Attaching the Wood Plank | *Coller la baguette de bois*

- 2.1 Screw the wood plank into the gap between both reception desks. | *Visser la baguette de bois dans l'espace entre les comptoirs de réception.*

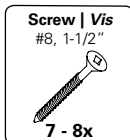
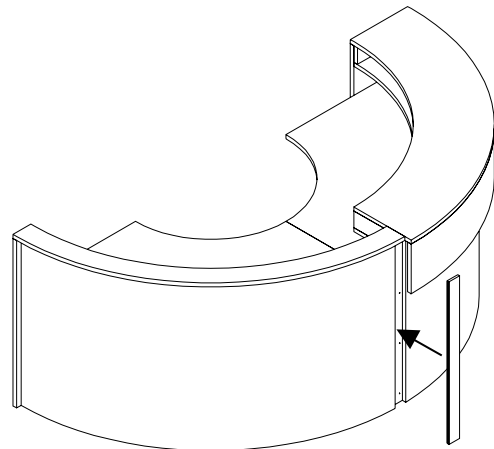

3 Attaching the Laminate Filler | *Coller la bande de remplissage en stratifié*

- 3.1 Remove the protective material on the back of the laminate filler strip. | *Enlever le matériel protecteur à l'endos de la bande de remplissage en stratifié.*
- 3.2 Stick the laminate filler on the wood plank. | *Coller la bande de remplissage en stratifié sur la baguette de bois.*

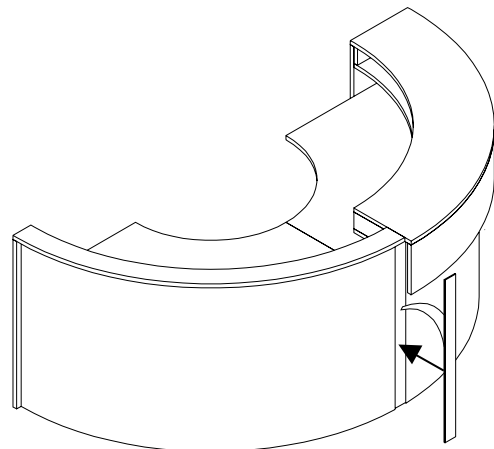

As our product line is constantly evolving and expanding, we recommend that you visit logiflex.ca for updates.
En raison de l'évolution constante des lignes de produits, Logiflex vous encourage à consulter les mises à jour au logiflex.ca.

logiflex

1235 St-Roch N., Sherbrooke QC J1N 0H2 Canada
T : 1.877.864.9323 | F : 1.800.474.7830 | logiflex.ca



INDOOR ADVANTAGE GOLD
FURNITURE