

logiflex

Components | Pièces

Support Panel
Panneau de support

Return
Retour

Transaction Shelf
Tablette de transaction

Front Panel
Façade

Desk
Bureau

Return with Transaction Shelf
Retour avec Tablette de transaction

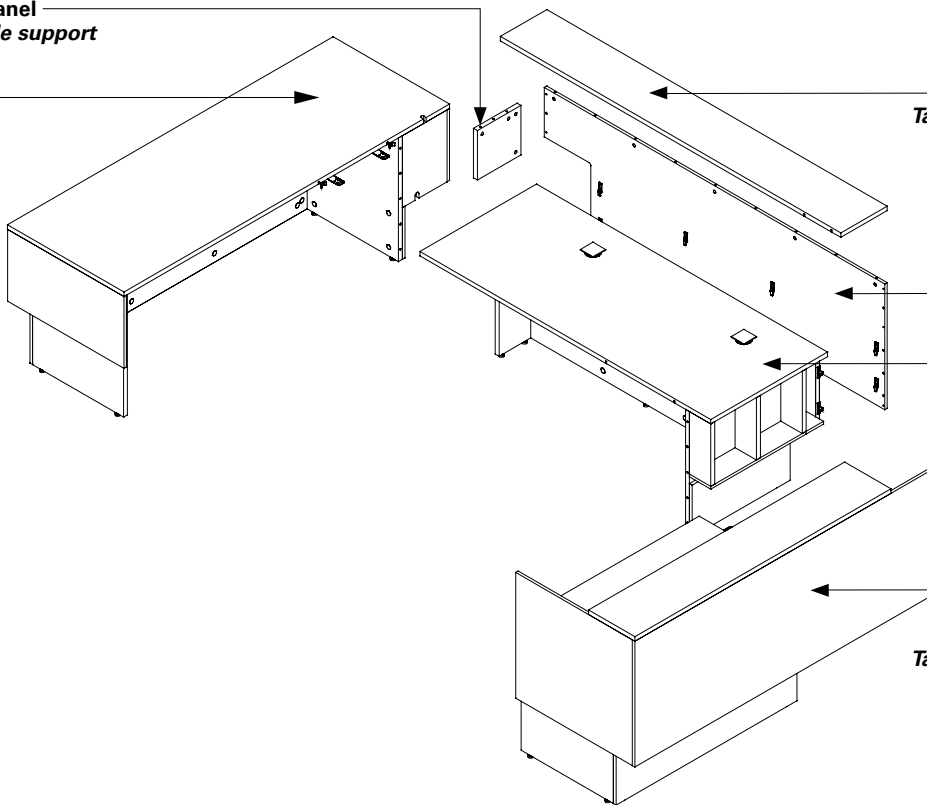

Hardware | Quincaillerie

Joint Fastener
Serre-joint

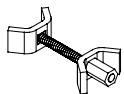

6x

Screw | Vis
#8 - 1"



12x

Double-Pin

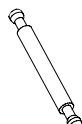

6x

Wood Dowel
Goujon de bois



13x

Pin Cam



12x

Cam



12x

Cam-Cover
Cache-Cam



21x

Screw | Vis
#8 - 1-1/2"



3x

Cam



6x

1 Assembling the Desk and Secondary Desks | Joindre le retour et le bureau.

- 1.1 Bring the 2 desks together. Make sure that both sides are level. | *Rassembler les 2 bureaux. Vérifier que les deux côtés sont de niveau.*
- 1.2 Assemble the desk with the pin Cams and wood dowels. | *Fixer les bureaux à l'aide des Cam et des goujons de bois.*
- 1.3 Tighten the Cams and hide them with Cam covers. | *Visser les Cam et coller les cache-Cam.*

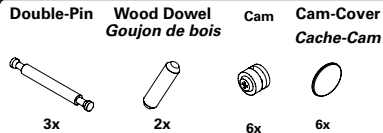
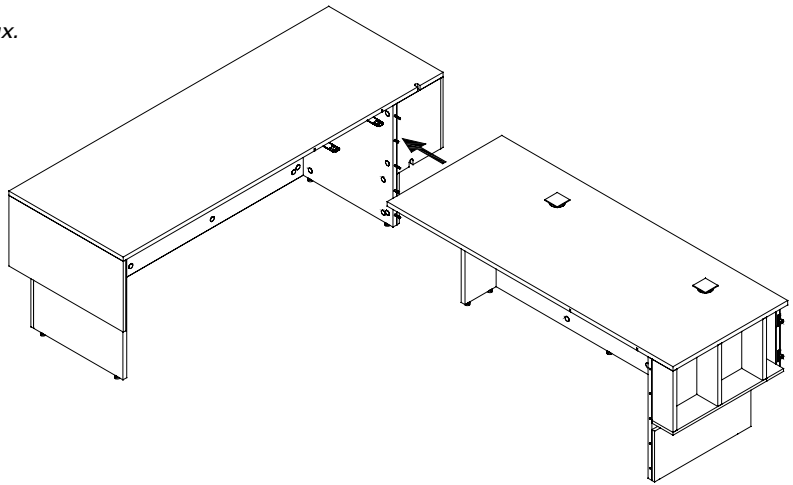

2 Secure the Desks | Fixer les bureaux

- 2.1 Insert the joint-fastener and tighten with 10mm (3/8") wrench. | *Insérer les serre-joints et serrer avec une clé de 10mm (3/8").*
- 2.2 Secure the junction plates under the secondary primary desk using the supplied screws. | *Fixer les plaques de jonction sous la surface du bureau secondaire avec les vis fournies.*

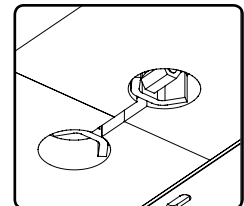
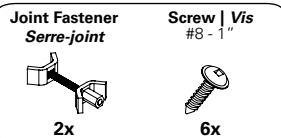
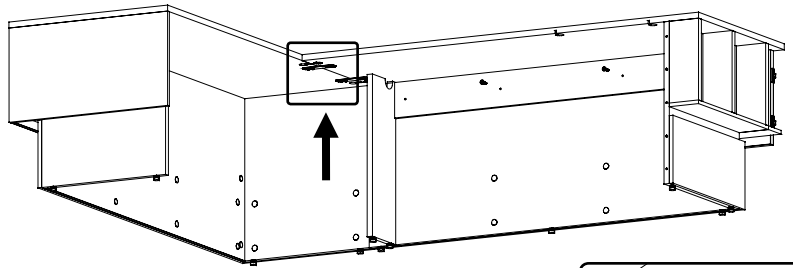

3 Clip on the Front Panel | Accrocher la façade

- 3.1 Clip the front panel into place by sliding the panel into position. | *Accrocher la façade en place en la faisant glisser.*

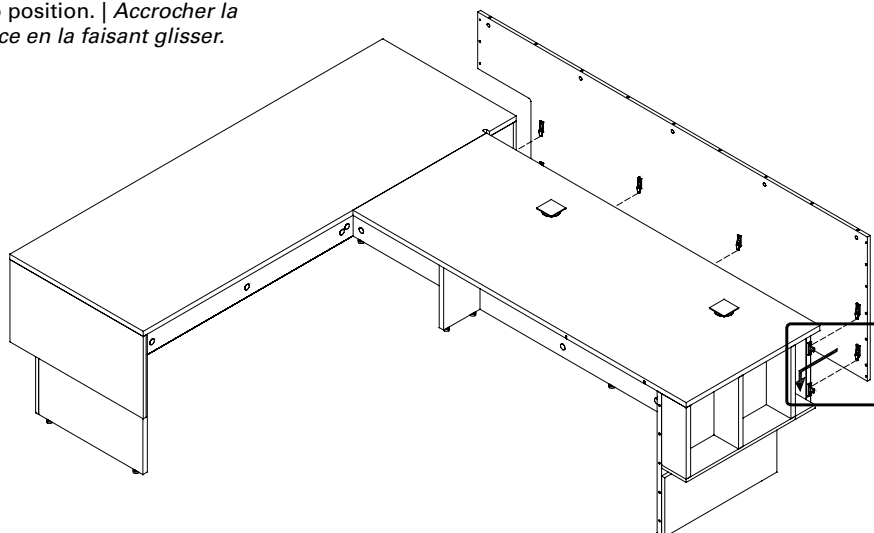

4 Securing the Front Panel to the Desk | Fixer la façade au bureau

4.1 Unscrew the supporting panel under the desk using a hexagonal key #4.
| *Dévisser le panneau de support sous le bureau à l'aide d'une clé hexagonale #4.*

4.1

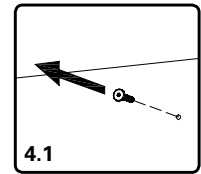
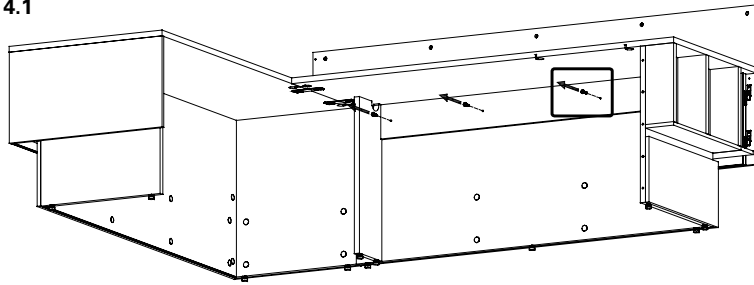

4.2 Secure the front panel to the desk using the supplied screws.
| *Fixez la façade au bureau à l'aide des vis fournies.*

4.2

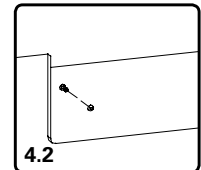
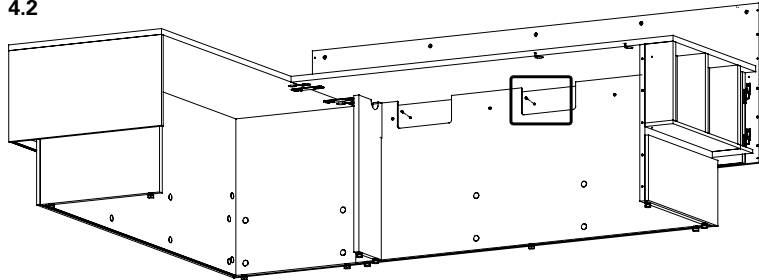

4.3 Restore the supporting panel to its place under the desk using the previously removed assembly bolt.
| *Remettez le panneau de support à sa place sous le bureau à l'aide des boulons d'assemblage précédemment retirés.*

4.3

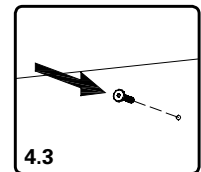
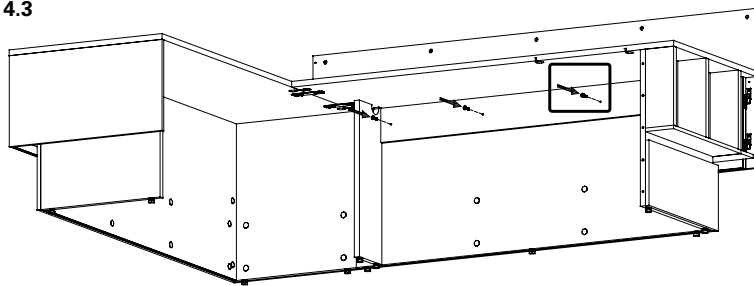

Screw | Vis
#8 - 1-1/2"



3x

5 Assembling the Return with the Transaction Shelf | Assemblage du retour avec tablette de transaction

5.1 Bring the return and the desk together.

Make sure that both sides are level.
| *Rassembler le retour et le bureau. Vérifier que les deux côtés sont de niveau.*

5.2 Assemble the desk with the pin Cams and wood dowels.
| *Fixer les bureaux à l'aide des Cam et des goujons de bois.*

5.3 Tighten the Cams and hide them with Cam covers.
| *Visser les Cam et coller les cache-Cam.*

5.4 Screw the junction plates under the primary desk and the return using the supplied screws.
| *Fixer les plaques de jonction sous la surface à l'aide des vis fournies.*

5.5 Insert the joint fastener and tighten with a 10mm (3/8") wrench.
| *Insérez le serre-joint et serrer avec une clé de 10mm (3/8").*

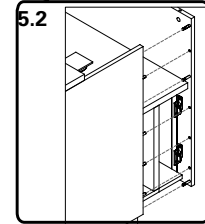
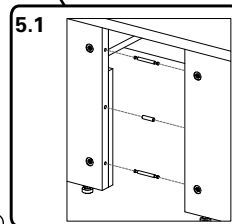
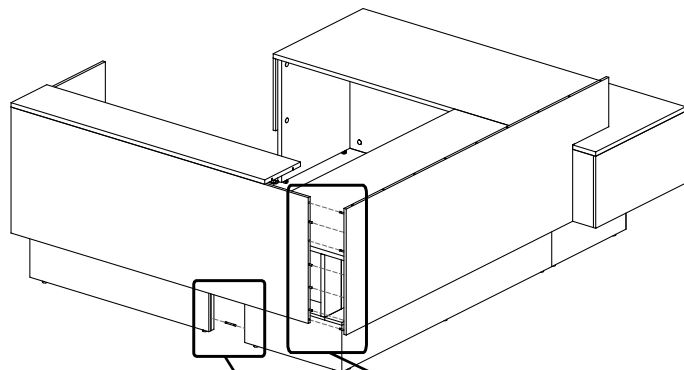

Joint Fastener Serre-joint	Screw Vis #8 - 1"	Pin Cam	Cam	Double-Pin	Cam-Cover Cache-Cam	Wood Dowel Goujon de bois	Cam
2x	6x	3x	3x	3x	6x	5x	6x

6 Securing Support Panel to the Desk | Installer le panneau de support

- 6.1** Insert the pin-Cams into the faceplate and the wood dowel into the support panel. ** To avoid breakage in the facade, it is important that the wood dowel is in the support panel (as shown) and not in the facade. ** | *Insérer les pin-Cam dans la façade et le goujon de bois dans le panneau de support. **Pour éviter les bris dans la façade, il est important que le goujon de bois se trouve dans le panneau de support (tel qu'illustré) et non dans la façade.***
- 6.2** Insert the Cams into the support panel and assemble it to the faceplate. | *Insérer les Cam dans le panneau de support et l'assembler à la façade.*
- 6.3** Hide the screw heads with Cam covers. | *Visser les Cam et coller les cache-Cam.*

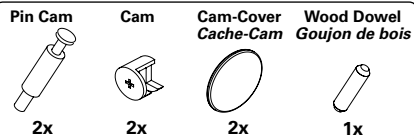
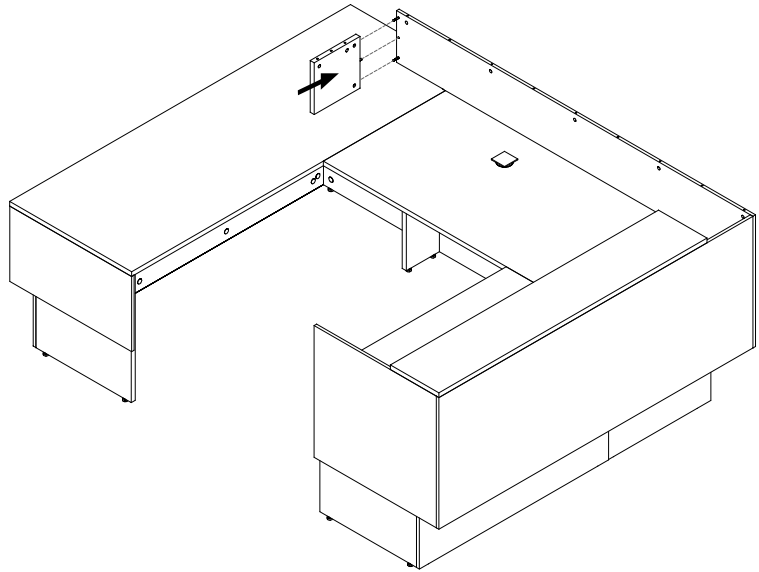

7 Install Transaction Top | Installer la tablette de transaction

- 7.1** Assemble the transaction top with the pin Cams and dowels. | *Installer la tablette de transaction à l'aide des Cam et des goujons de bois.*
- 7.2** Tighten the Cams and hide them with Cam covers. | *Visser les Cam et coller les cache-Cam.*
- 7.3** Insert the joint fastener and tighten with a 10mm (3/8") wrench. | *Insérez les serre-joints et serrer avec un clé de 10mm (3/8").*

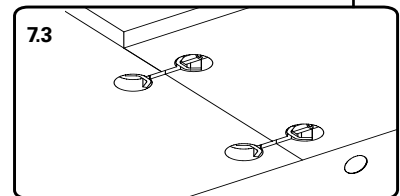
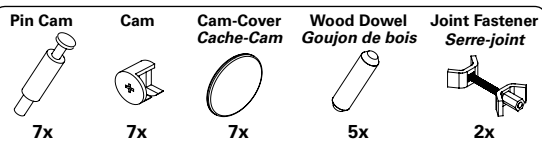
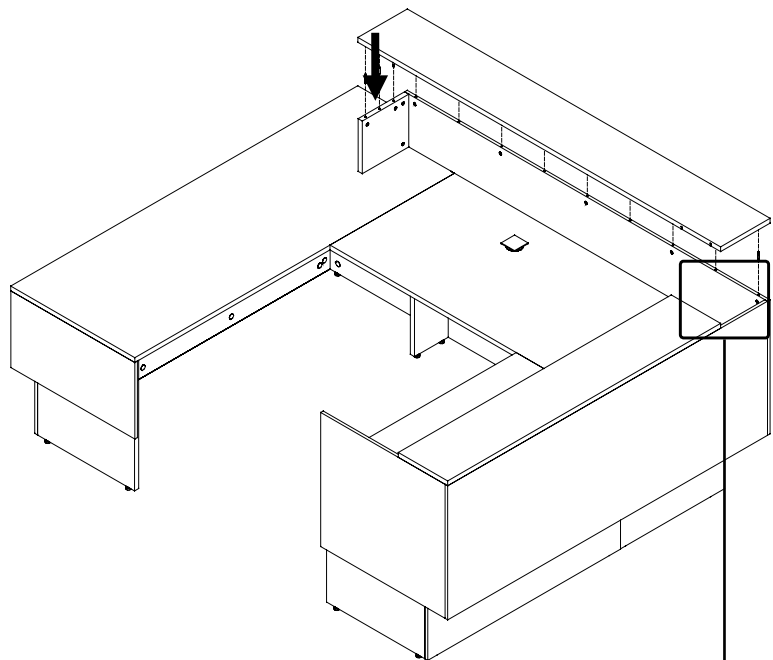

As our product line is constantly evolving and expanding, we recommend that you visit logiflex.ca for updates.
En raison de l'évolution constante des lignes de produits, Logiflex vous encourage à consulter les mises à jour au logiflex.ca.

logiflex

1235 St-Roch N., Sherbrooke QC J1N 0H2 Canada
T : 1.877.864.9323 | F : 1.800.474.7830 | logiflex.ca



INDOOR ADVANTAGE GOLD
FURNITURE

LED Installation - INBOX in U (INBU)
Installation DEL - INBOX en U (INBU)

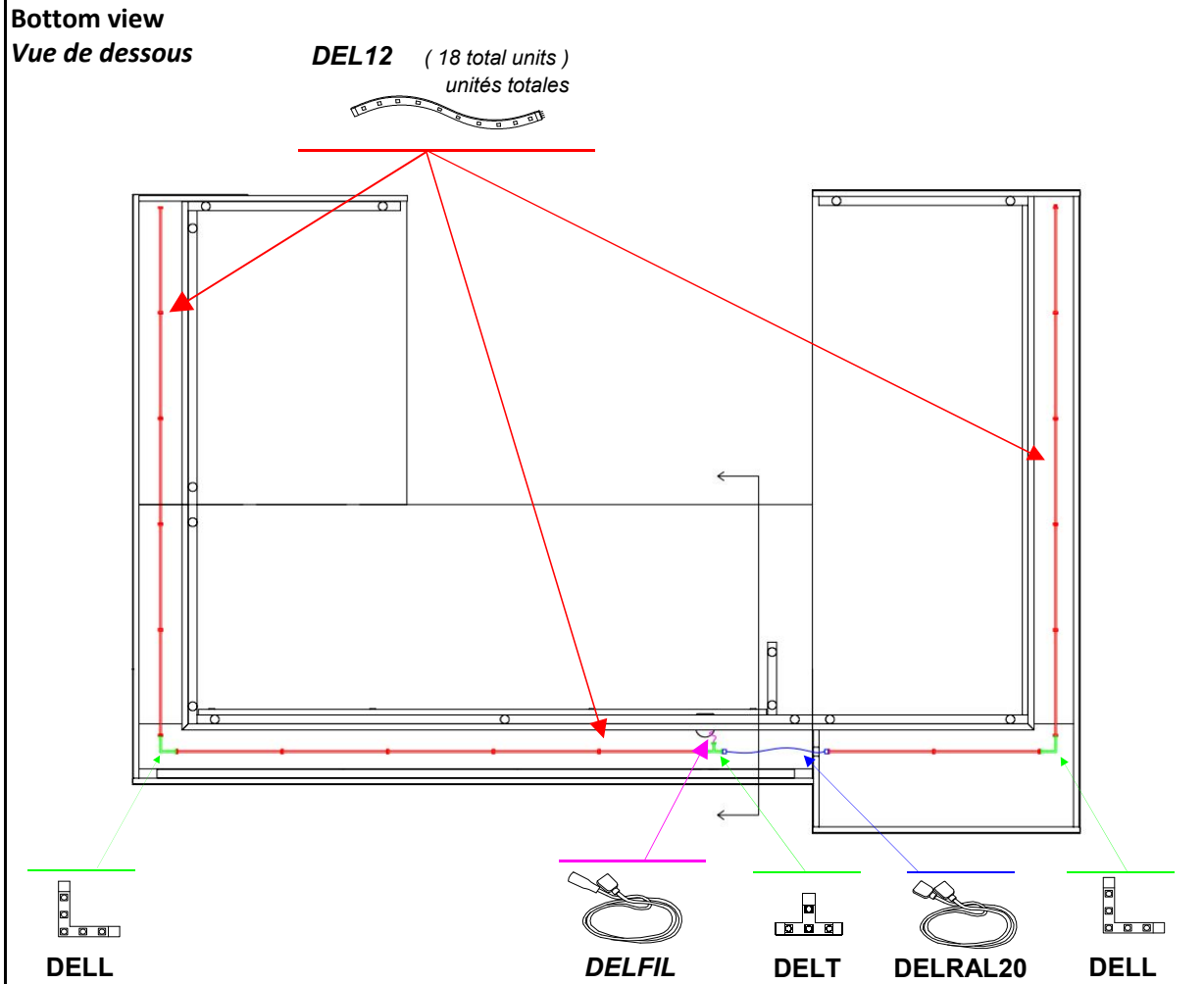
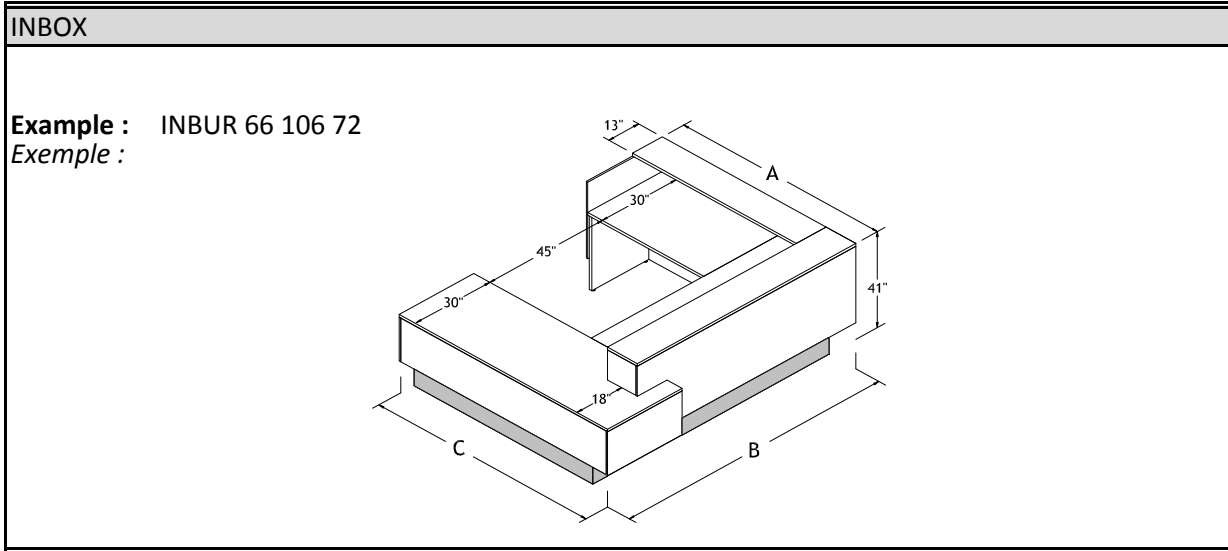

LED Installation - INBOX in U (INBU)
Installation DEL - INBOX en U (INBU)

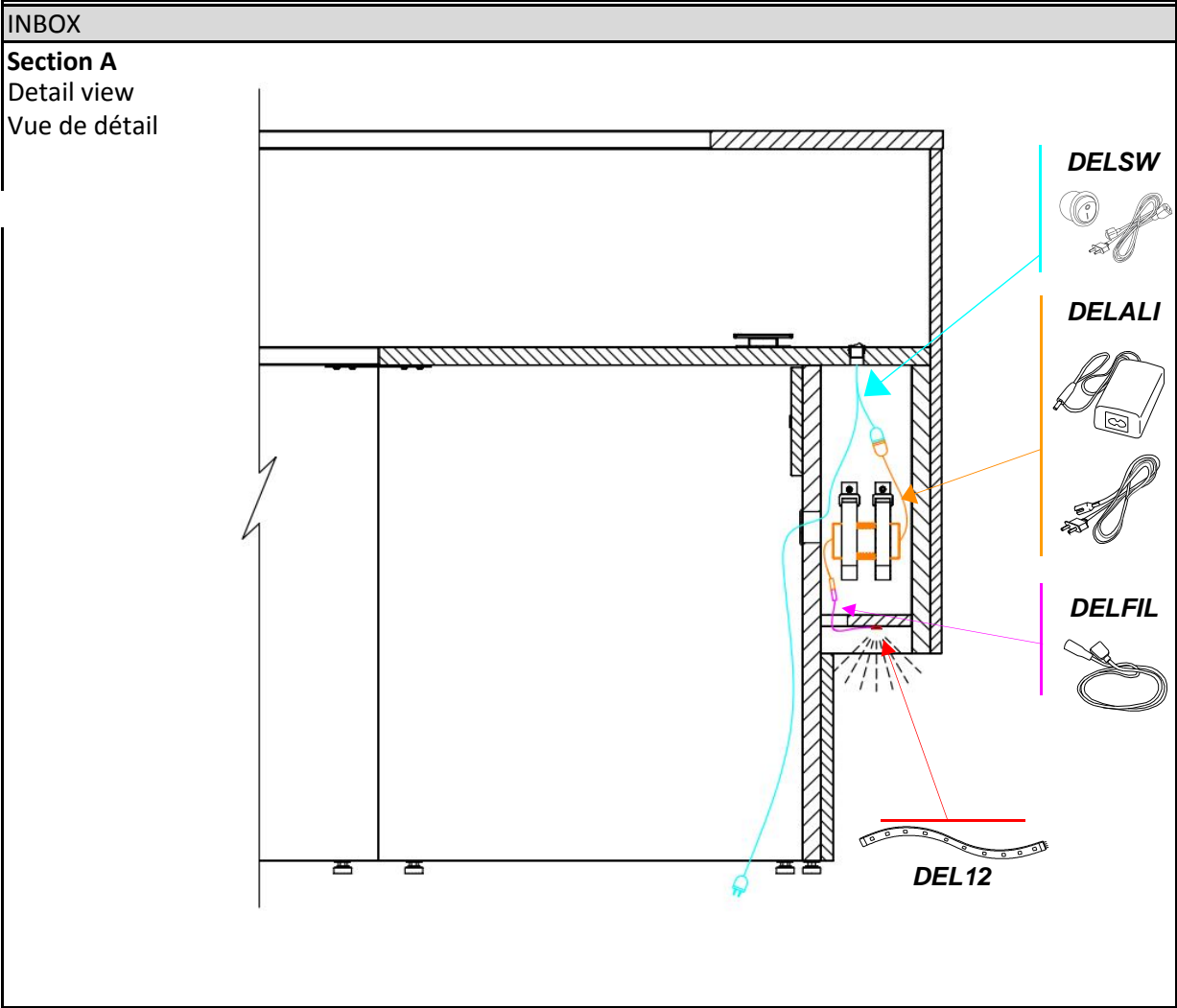

LED Components - Items purchased
Composants DEL - Items Achetés



STARTER KIT/KIT DE DÉPART		
DELALI * Maximum of 20 units of DEL12 for a DELALI Maximum de 20 unités de DEL12 pour un DELALI	DELSW On/Off Rocker Switch Interrupteur à bascule	DELFIL Wire that connects the switch to LED tape or connector / Fil qui relie l'interrupteur et les bandes ou raccords DEL.
Wire length/Longueur fil = 40"	Wire length/Longueur fil = 40" + Block 3.5"	Wire length/Longueur fil = 79"

Flexible LED Tape 2.4w / Bande de DEL flexible 2.4w	
DEL12 * Maximum of 20 units of DEL12 for a DELALI Maximum de 20 unités de DEL12 pour un DELALI	The DEL12 strip can be cut to 6 inch. Nothing can be reconnected there / La Bande de DEL12 peut-être recoupée à 6 pouce. Rien ne peut-être reconnecté à cet endroit.
Each flexible LED strip is manufactured with male and female ends. It is not necessary to use connectors. / Chaque ruban de DEL flexible est fabriqué avec les extrémités mâle et femelle. Il n'est pas nécessaire d'utiliser des broches de connexion.	<p>Important : to cut on the line / à couper sur la ligne</p>

Various Accessories for Flexible LED 2.4w / Accessoires divers pour DEL flexible 2.4w	
<p>DELL 90 ° L-joint to use in corners. Dimension : [1-7/8" x 1-7/8"] Three quick connectors are included.</p> <p>Raccord de "L" à 90° à utiliser dans les coins. Dimension : [1-7/8" x 1-7/8"] Trois broches à connexion rapide sont incluses.</p>	<p>Example of quick interconnect pins Exemple de broches à connexion rapide</p>
<p>X-Joint to connect four directions. Dimension : [2" x 2"] Three quick connectors are included.</p> <p>Raccord en "X" pour brancher dans quatre directions. Dimension : [2" x 2"] Trois broches à connexion rapide sont incluses.</p>	
<p>DELT T-joint to link three directions. Dimension : [2" x 1-1/8"] Three quick connectors are included.</p> <p>Raccord en "T" pour brancher dans trois directions. Dimension : [2" x 1-1/8"] Trois broches à connexion rapide sont incluses.</p>	
<p>DELRAL20 20" extension / Rallonge de 20" DELRAL40 40" extension / Rallonge de 40" DELRAL79 79" extension / Rallonge de 79"</p> <p>Useful for connecting two furniture sections. / Utile pour raccorder deux sections de meuble</p>	
<p>Extensions and connectors are manufactured with female ends. It is necessary to use the quick interconnect pins. / Les rallonges et les raccords sont fabriqués avec les extrémités femelle. Il est nécessaire d'utiliser les broches de connexion.</p>	