

INBL

Assembly Instructions  
Instructions d'assemblage

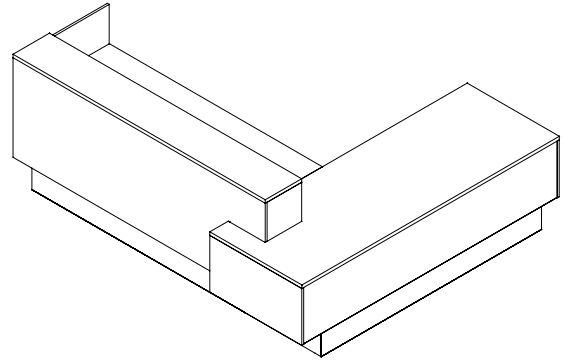

logiflex

Components | Pièces

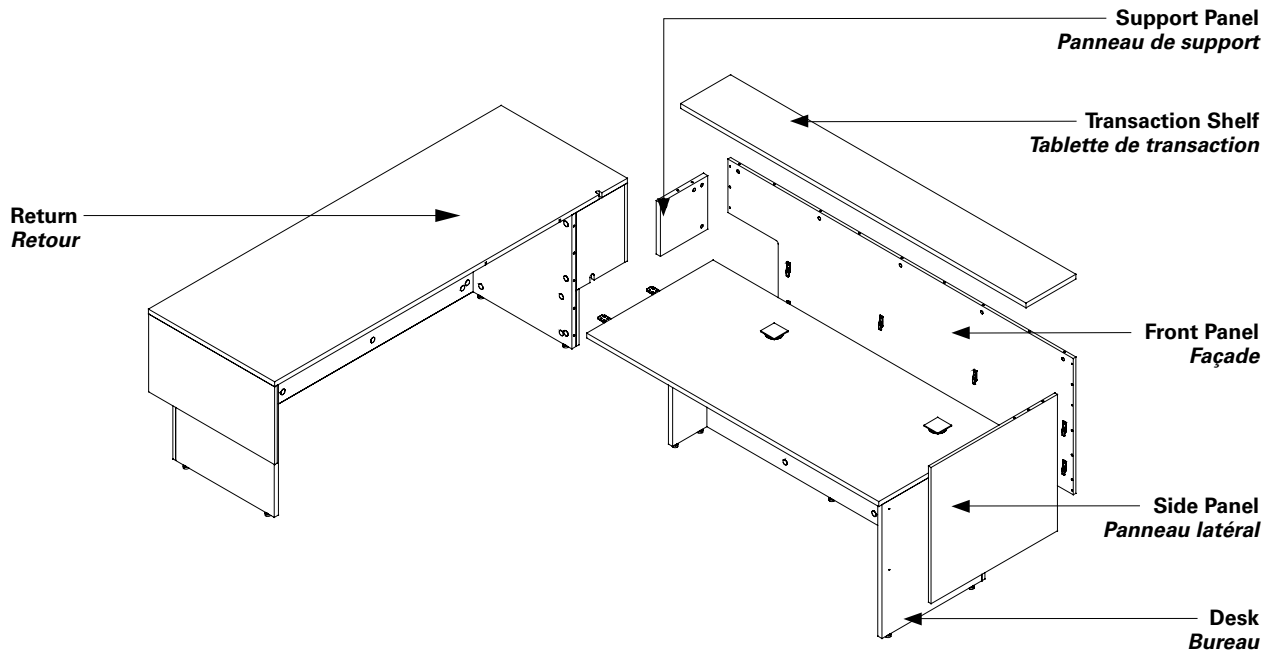

Hardware | Quincaillerie

Joint Fastener Serre-joint	Juction Plate Plaque de jonction	Screw   Vis #8 - 1"	Double-Pin Cam Goujon de bois	Wood Dowel Goujon de bois	Pin Cam	Cam	Cam-Cover Cache-Cam	Screw   Vis #8 - 1-1/2"	Screw   Vis 30mm, 1/4" - 20	
2x	2x	8x	3x	6x	12x	15x	15x	25x	7x	4x

## 1 Assembling the Desk and Secondary Desks | Joindre le retour et le bureau

- 1.1 Screw the junction plates under the primary desk using the supplied screws. | *Fixer les plaques de jonction sous la surface à l'aide des vis fournies.*
- 1.2 Bring the 2 desks together. Make sure that both sides are level. | *Rassembler les 2 bureaux. Vérifier que les deux côtés sont de niveau.*
- 1.3 Assemble the desk with the pin Cams and wood dowels. | *Fixer les bureaux à l'aide des Cam et des goujons de bois.*
- 1.4 Tighten the Cams and hide them with Cam covers. | *Visser les Cam et coller les cache-Cam.*

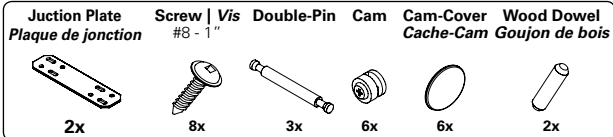
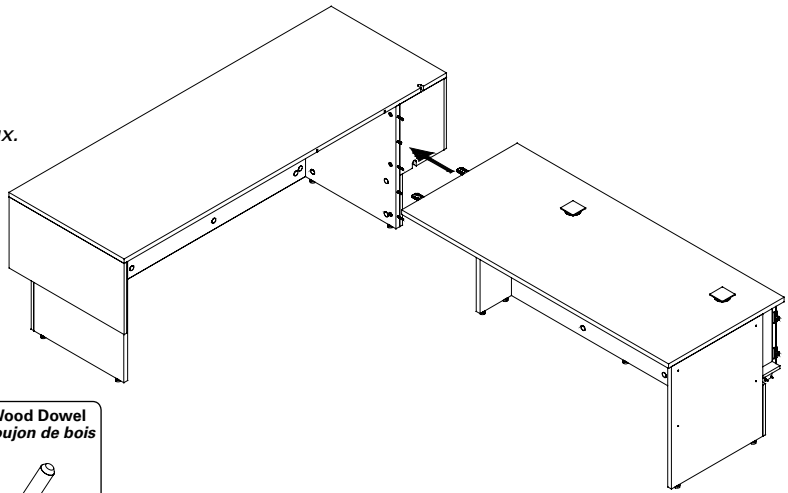

## 2 Secure the Desks | Fixer les bureaux

- 2.1 Insert the joint-fastener and tighten with 10mm (3/8") wrench. | *Insérer le serre-joint du bureau secondaire avec les vis fournies.*
- 2.2 Secure the junction plates under the secondary primary desk using the supplied screws. | *Fixer les plaques de jonction sous la surface du bureau secondaire avec les vis fournies.*

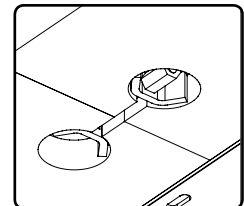
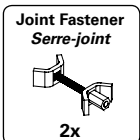
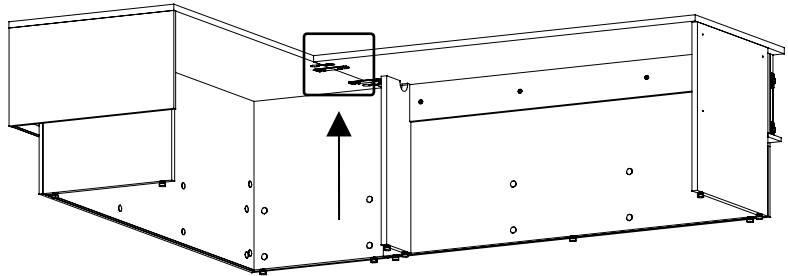

## 3 Clip on the Front Panel | Accrocher la façade

- 3.1 Clip the front panel into place by sliding the panel into position. | *Accrocher la façade en place en le faisant glisser.*

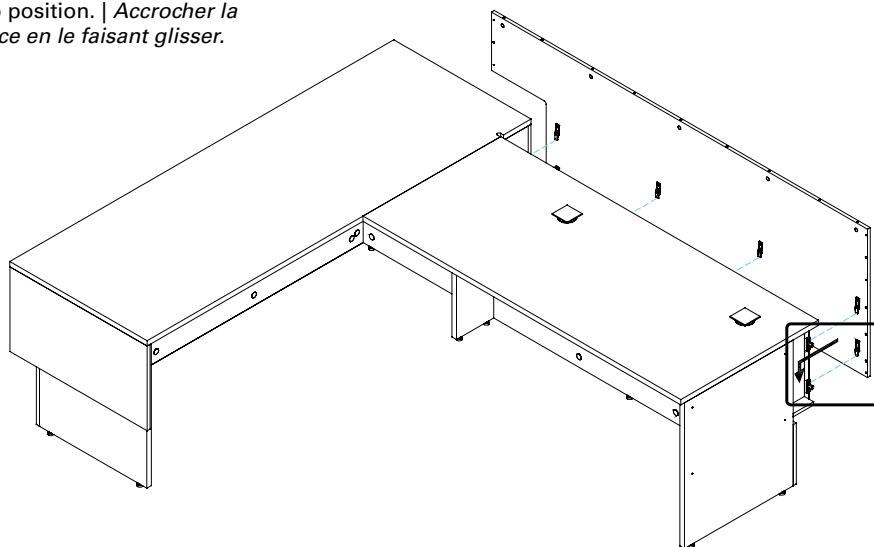

**4 Securing the Front Panel to the Desk | Fixer la façade au bureau**

- 4.1 Unscrew the supporting panel under the desk. | *Dévisser le panneau de support sous le bureau.*
- 4.2 Secure the front panel to the desk using the supplied screws. | *Fixez la façade au bureau à l'aide des vis fournies.*
- 4.3 Restore the supporting panel to its place under the desk using the previously removed screws. | *Remettez le panneau de support à sa place sous le bureau à l'aide des vis précédemment retirées.*

4.1

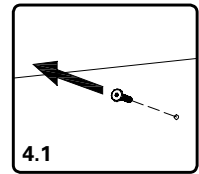
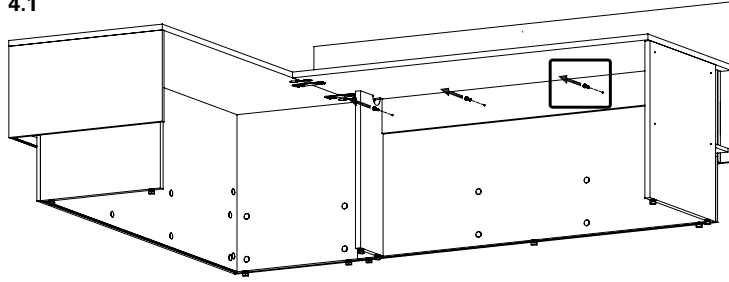

4.1

4.2

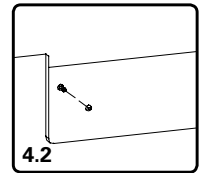
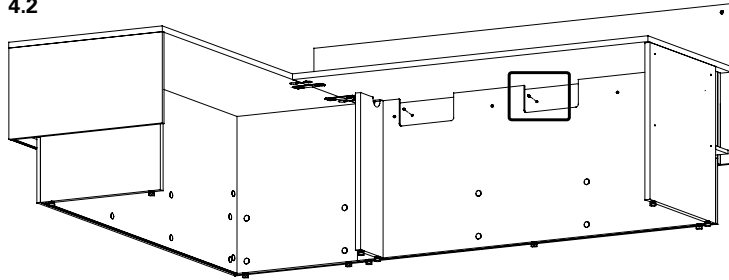

4.2

4.3

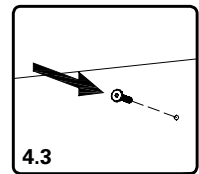
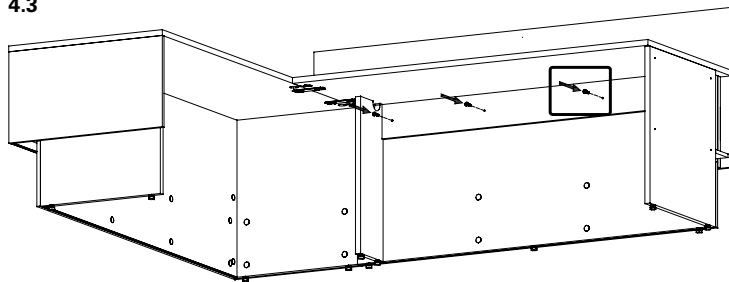

4.3

Screw | Vis  
#8 - 1-1/2"



3x

**5 Securing the Front Panel to the Desk | Installer le panneau de support et le panneau latéral**

- 5.1 Assemble the support panel and side panels to the front panel with the pin Cams and dowels. | *Assemblez le panneau de support et le panneau latéral à l'aide des Cam et des goujons de bois.*
- 5.2 Tighten the Cams and hide them with Cam covers. | *Visser les Cam et coller les cache-Cam.*

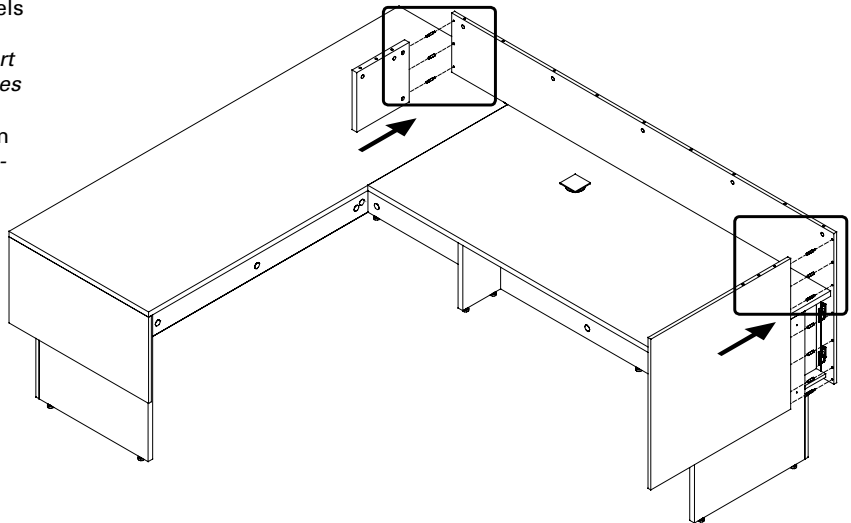

- |                |            |                                |                                      |
|----------------|------------|--------------------------------|--------------------------------------|
| <b>Pin Cam</b> | <b>Cam</b> | <b>Cam-Cover<br/>Cache-Cam</b> | <b>Wood Dowel<br/>Goujon de bois</b> |
|                |            |                                |                                      |
| 5x             | 5x         | 5x                             | 5x                                   |

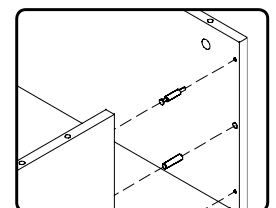
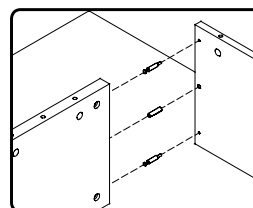

## 6 Securing Side Panel to the Desk | Sécourir le panneau latéral au bureau

- 6.1 Secure the inside panel to the desk using the supplied screws. | Assemblez le panneau latéral à l'aide des vis fournies.
- 6.2 Hide the screw heads with Cam covers. | Coller les cache-Cam.

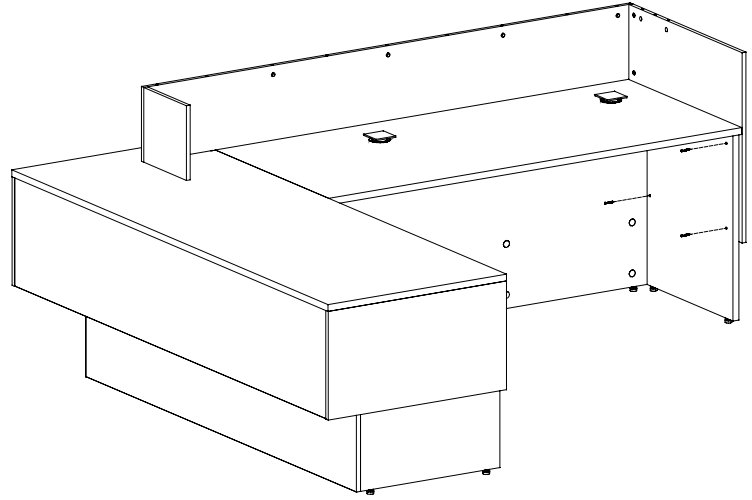

Screw | Vis  
#8 - 1-1/2"



4x

Cam-Cover  
Cache-Cam



4x

## 7 Install Transaction Top | Installer la tablette de transaction

- 7.1 Assemble the transaction top with the pin Cams and dowels. | Installer la tablette de transaction à l'aide des Cam et des goujons de bois.
- 7.2 Tighten the Cams and hide them with Cam covers. | Visser les Cam et coller les cache-Cam.

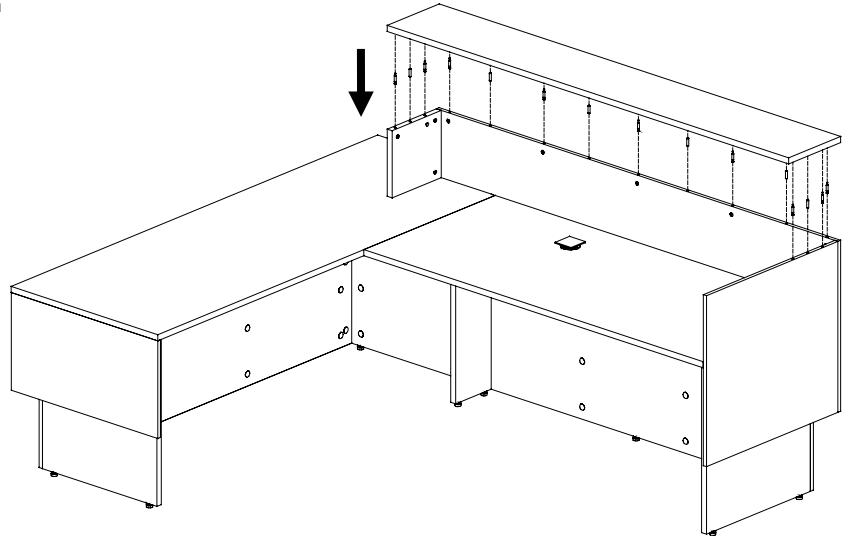

Pin Cam



9x

Cam



9x

Cam-Cover  
Cache-Cam



9x

Wood Dowel  
Goujon de bois



6x

As our product line is constantly evolving and expanding, we recommend that you visit [logiflex.ca](http://logiflex.ca) for updates.  
En raison de l'évolution constante des lignes de produits, Logiflex vous encourage à consulter les mises à jour au [logiflex.ca](http://logiflex.ca).

logiflex

1235 St-Roch N., Sherbrooke QC J1N 0H2 Canada  
T : 1.877.864.9323 | F : 1.800.474.7830 | [logiflex.ca](http://logiflex.ca)



**LED Installation - INBOX in L (INBL)**  
**Installation DEL - INBOX en L (INBL)**

logiflex

**INBOX**

**Example :** 88 72 INBL R

**Exemple :**

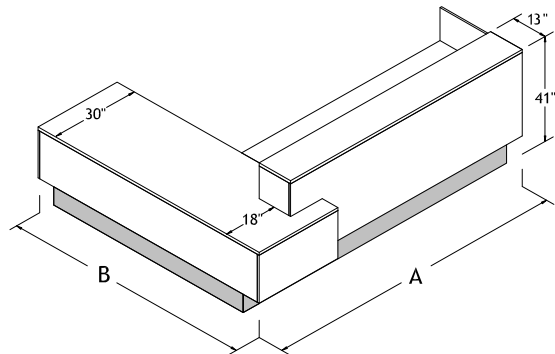

**Bottom view**  
**Vue de dessous**

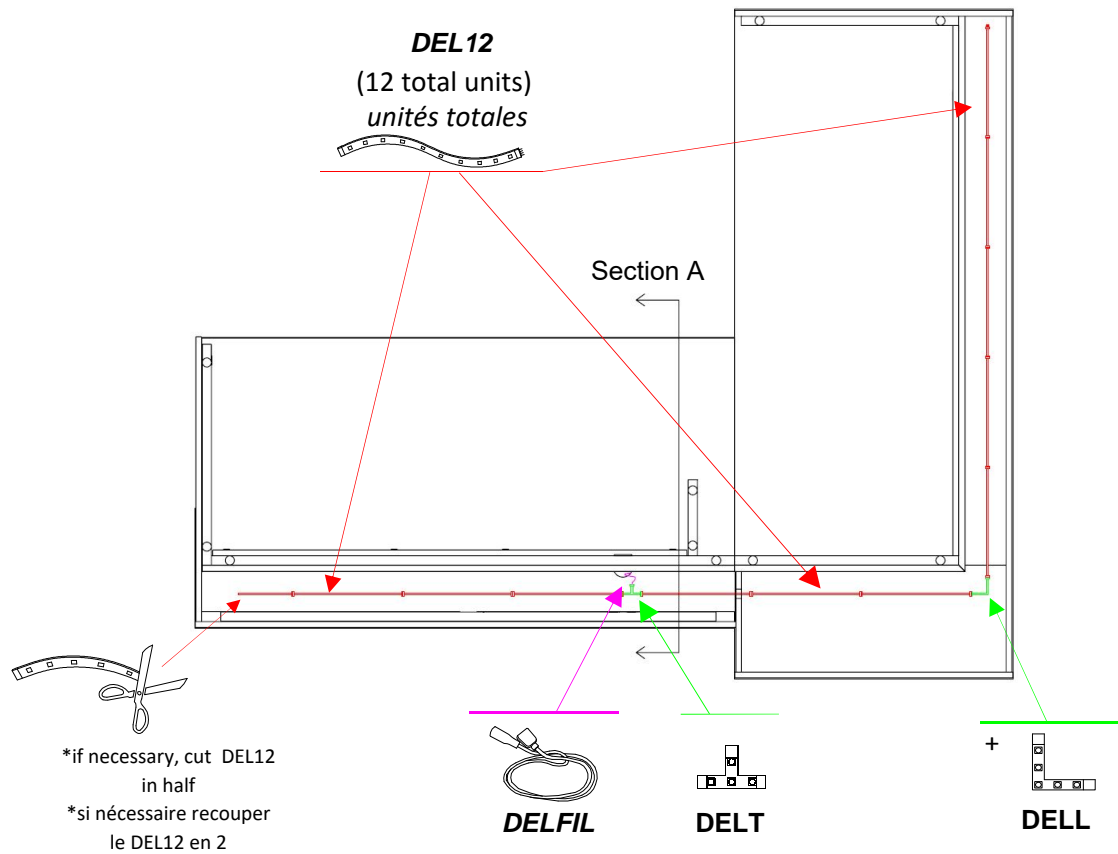

**LED Installation - INBOX en L (INBL)**  
**Installation DEL - INBOX en L (INBL)**

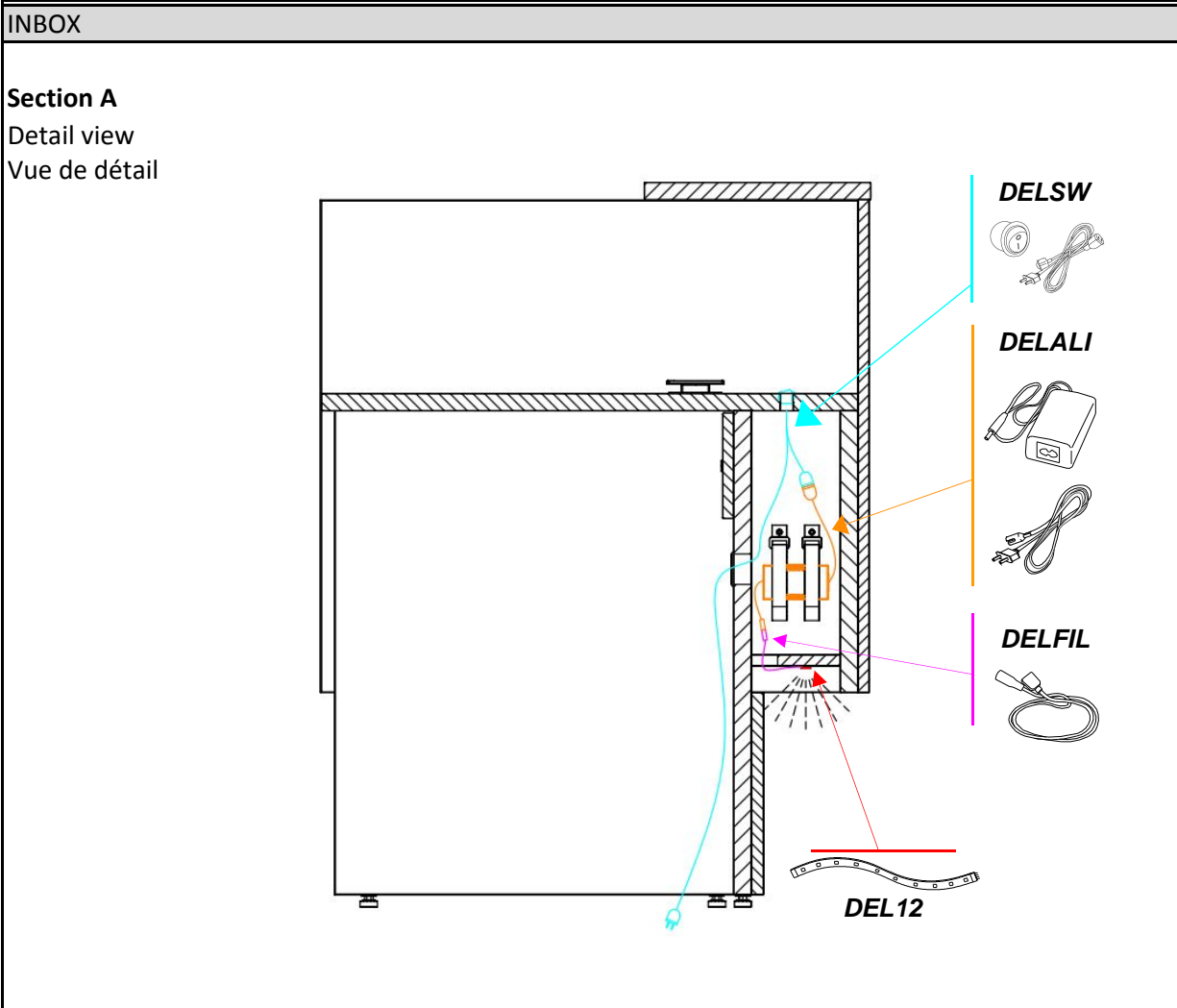

**LED Components - Items purchased**  
**Composants DEL - Items Achetés**



STARTER KIT/KIT DE DÉPART		
<b>DELALI</b> * Maximum of 20 units of DEL12 for a DELALI Maximum de 20 unités de DEL12 pour un DELALI	<b>DELSW</b> On/Off Rocker Switch Interrupteur à bascule	<b>DELFIL</b> Wire that connects the switch to LED tape or connector / Fil qui relie l'interrupteur et les bandes ou raccords DEL.
Wire length/Longueur fil = 40"	Wire length/Longueur fil = 40" + Block 3.5"	Wire length/Longueur fil = 79"

Flexible LED Tape 2.4w / Bande de DEL flexible 2.4w	
<b>DEL12</b> * Maximum of 20 units of DEL12 for a DELALI Maximum de 20 unités de DEL12 pour un DELALI	<i>The DEL12 strip can be cut to 6 inch. Nothing can be reconnected there / La Bande de DEL12 peut-être recoupée à 6 pouce. Rien ne peut-être reconnecté à cet endroit.</i>
Each flexible LED strip is manufactured with male and female ends. It is not necessary to use connectors. / Chaque ruban de DEL flexible est fabriqué avec les extrémités mâle et femelle. Il n'est pas nécessaire d'utiliser des broches de connexion.	<p><b>Important : to cut on the line / à couper sur la ligne</b></p>

Various Accessories for Flexible LED 2.4w / Accessoires divers pour DEL flexible 2.4w	
<p><b>DELL</b> 90 ° L-joint to use in corners. Dimension : [1-7/8" x 1-7/8"] Three quick connectors are included.</p> <p><i>Raccord de "L" à 90° à utiliser dans les coins. Dimension : [1-7/8" x 1-7/8"] Trois broches à connexion rapide sont incluses.</i></p>	<p>Example of quick interconnect pins Exemple de broches à connexion rapide</p>
<p><b>X-Joint</b> to connect four directions. Dimension : [2" x 2"] Three quick connectors are included.</p> <p><i>Raccord en "X" pour brancher dans quatre directions. Dimension : [2" x 2"] Trois broches à connexion rapide sont incluses.</i></p>	
<p><b>DELT</b> T-joint to link three directions. Dimension : [2" x 1-1/8"] Three quick connectors are included.</p> <p><i>Raccord en "T" pour brancher dans trois directions. Dimension : [2" x 1-1/8"] Trois broches à connexion rapide sont incluses.</i></p>	
<p><b>DELRAL20</b> 20" extension / Rallonge de 20"  <b>DELRAL40</b> 40" extension / Rallonge de 40"  <b>DELRAL79</b> 79" extension / Rallonge de 79"</p> <p><i>Useful for connecting two furniture sections. / Utile pour raccorder deux sections de meuble</i></p>	
<p>Extensions and connectors are manufactured with female ends. It is necessary to use the quick interconnect pins. / Les rallonges et les raccords sont fabriqués avec les extrémités femelle. Il est nécessaire d'utiliser les broches de connexion.</p>	